

Pneumatic Parallel Grippers

OPH 2-Finger

OPH is a sealed two-finger parallel gripper featuring high reliability that is suitable for handling rough/dirty workpieces.

Advantages

- IP67 protection provided by rotary lip seals at both round jaws offer permanent, secure protection.
- Side finger-mounting.
- Compact dimensions for minimal impact in space sensitive applications.
- Mounting from two sides in three screw directions for versatile and flexible integration.
- Integrated permanent magnets for direct monitoring of piston movement.
- Slots for mounting and positioning of magnetic-field sensors.
- Air supply via hose-free direct connections or fitting screw connections.

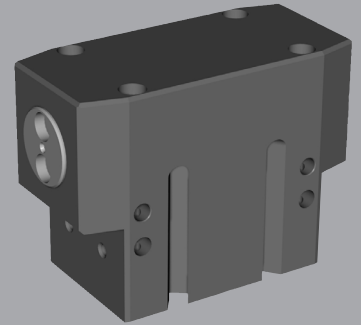

SPECIFICATIONS

Model	Stroke Per Jaw	Air Consumption Per Cycle (Dual Stroke)	Closing Force Per Jaw @ 6 bar	Opening Force Per Jaw @ 6 bar	Total Closing Force @ 6 bar	Total Opening Force @ 6 bar	Recommended Workpiece Weight*	Weight	Repeatability
OPH 73	6 mm	7.3 cm ³	100 N	111 N	200 N	222 N	1.00 kg	0.48 kg	± 0.01 mm
	0.24 in	0.45 in ³	22.5 lb	25.0 lb	45.0 lb	49.9 lb	2.20 lb	1.06 lb	± 0.0004 in
OPH 88	8 mm	16.5 cm ³	174 N	191 N	348 N	382 N	1.74 kg	0.70 kg	± 0.01 mm
	0.31 in	1.01 in ³	39.1 lb	42.9 lb	78.2 lb	85.9 lb	3.80 lb	1.54 lb	± 0.0004 in
OPH 108	10 mm	31.9 cm ³	268 N	292 N	536 N	584 N	2.68 kg	1.40 kg	± 0.01 mm
	0.39 in	1.95 in ³	60.2 lb	65.6 lb	120.5 lb	131.3 lb	5.90 lb	3.08 lb	± 0.0004 in
OPH 133	12 mm	59.4 cm ³	414 N	446 N	828 N	892 N	4.14 kg	2.30 kg	± 0.01 mm
	0.47 in	3.62 in ³	93.1 lb	100.3 lb	186.1 lb	200.5 lb	9.10 lb	5.06 lb	± 0.0004 in

* Recommended workpiece weight is calculated for force-fit gripping with a coefficient of static friction of 0.15 and a safety factor of 3 against workpiece slippage.

Operating Pressure **2 - 8 bar (29 - 116 psi)**

Working Temperature **5 - 60 °C (41 - 140 °F)**

Noise Emission (Sound Pressure) **≤ 70 dB(A) in any direction**

SECTIONAL DIAGRAM

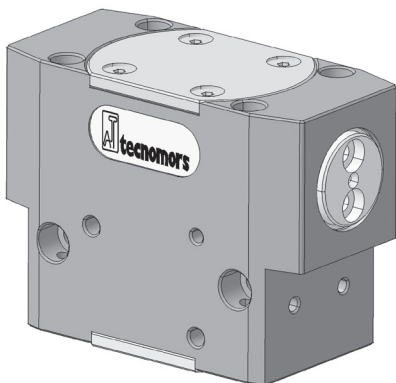

Guidelines for the selection of a gripper model
 Selection of the correct gripper model depends on the workpiece's weight, the friction coefficient between the fingers and the workpiece and the required motion of the application. Due to inertial forces associated with motion, we recommend that the holding force of the gripper model should be from 10 to 20 times the workpiece's weight. If the application presents high acceleration/deceleration or impacts during the motion, then a further safety margin should be considered.

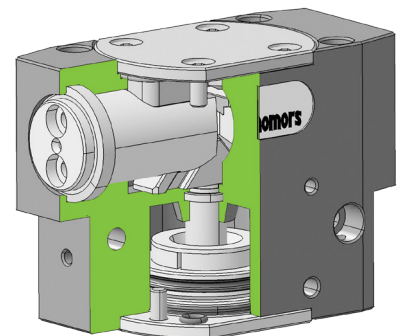

PRODUCT INFORMATION

OPH 2-Finger

Body dowel hole depth $\geq 1.5 d$

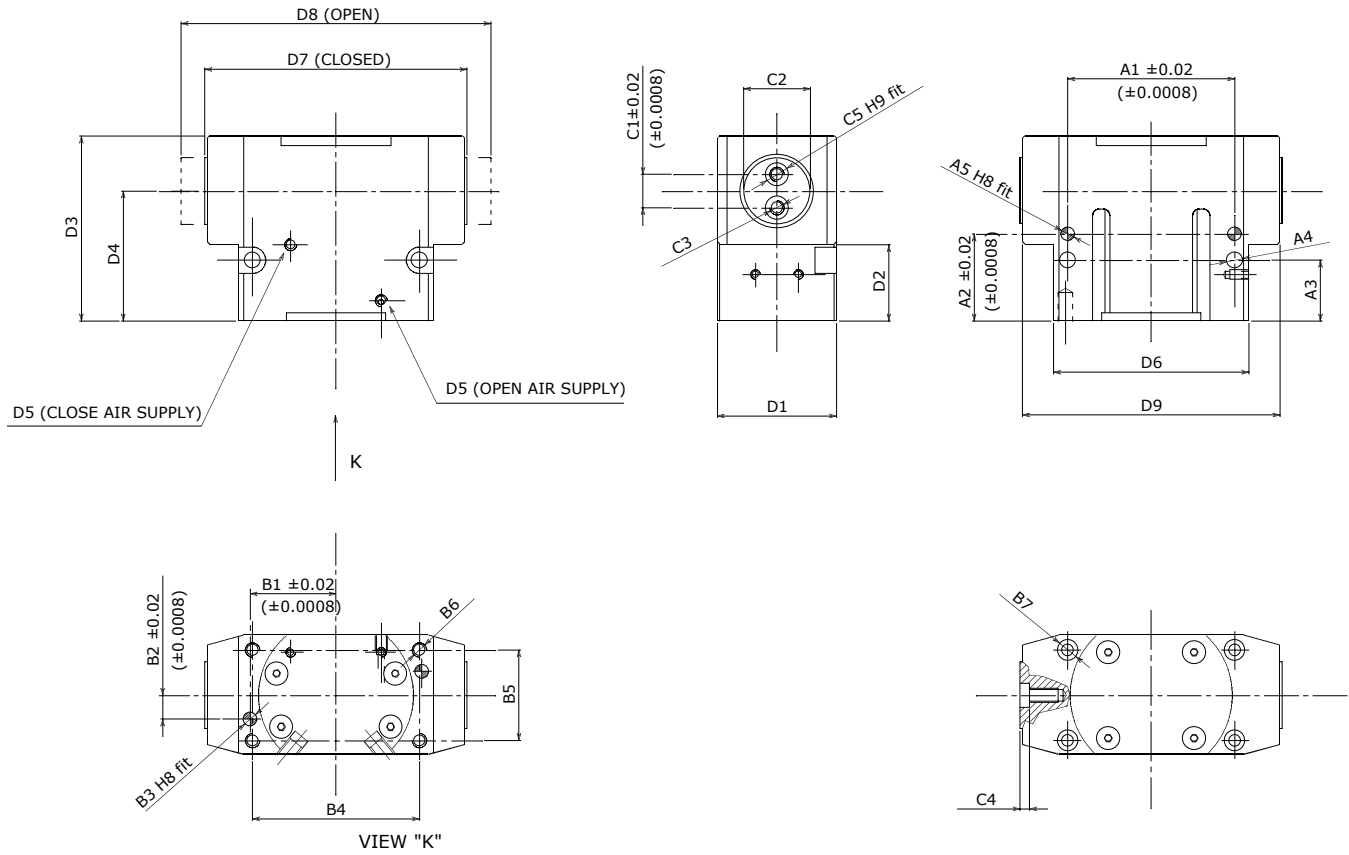

Options

- Magnetic switches

	Mounting - Option # 1					Mounting - Option # 2						
	A1	A2	A3	A4	A5	B1	B2	B3	B4	B5	B6	B7
OPH 73	23 (0.91)	27.5 (1.08)	19.5 (0.77)	4.5 (0.18)	4 (0.16)	23.00 (0.91)	6.5 (0.26)	4 (0.16)	44 (1.73)	27 (1.06)	M5	7.6 (0.30)
OPH 88	29 (1.14)	32 (1.26)	22 (0.87)	5.5 (0.22)	5 (0.20)	29.00 (1.14)	8 (0.31)	5 (0.20)	54 (2.13)	32 (1.26)	M5	7.4 (0.29)
OPH 108	36 (1.42)	36.5 (1.44)	25.5 (1.00)	6.5 (0.26)	6 (0.24)	36.00 (1.42)	10 (0.39)	6 (0.24)	70 (2.76)	38 (1.50)	M6	9 (0.35)
OPH 133	46 (1.81)	43 (1.69)	31 (1.22)	8.5 (0.33)	8 (0.31)	26.00 (80.00)	11 (0.43)	8 (0.31)	90 (3.54)	46 (1.81)	M8	11 (0.43)

	Finger Application					Informational Dimensions								
	C1	C2	C3	C4	C5	D1	D2	D3	D4	D5	D6	D7	D8	D9
OPH 73	10 (0.39)	18 (0.71)	M4	3 (0.12)	6 (0.24)	36 (1.42)	24 (0.94)	56 (2.20)	39.5 (1.56)	M5	52 (2.05)	75 (2.95)	87 (3.43)	73 (2.87)
OPH 88	12 (0.47)	22 (0.87)	M5	3 (0.12)	8 (0.31)	42 (1.65)	28.5 (1.12)	65.5 (2.58)	47 (1.85)	M5	65 (2.56)	90 (3.54)	106 (4.17)	88 (3.46)
OPH 108	14 (0.55)	28 (1.10)	M6	4 (0.16)	10 (0.39)	50 (1.97)	32 (1.26)	77.5 (3.05)	54.5 (2.15)	M5	82 (3.23)	110 (4.33)	130 (5.12)	108 (4.25)
OPH 133	16 (0.63)	32 (1.26)	M8	4 (0.16)	12 (0.47)	60 (2.36)	38.5 (1.52)	90 (3.54)	64 (2.52)	G1/8	105 (4.13)	135 (5.31)	159 (6.26)	133 (5.24)

* Dimensions are in millimeters (inches).

** All dimensions are descriptive and subject to variation for technical upgrading. We reserve the right to make variations without prior notification



Applied Robotics

648 Saratoga Road
Glenville, NY 12302 USA

Tel. +1 518 384 1000 Fax +1.5183841200
info@appliedrobotics.com
www.appliedrobotics.com



EFFECTO GROUP S.p.A.

Via Roma, 141/143
28017 San Maurizio d'Opaglio (NO) - Italy
Tel. +39 0322 96142 Fax +39 0322 967453

info@effectogroup.com
www.effecto.com

